

KRX20 Series 2-Pin/3-Pin Connector Operation Instruction

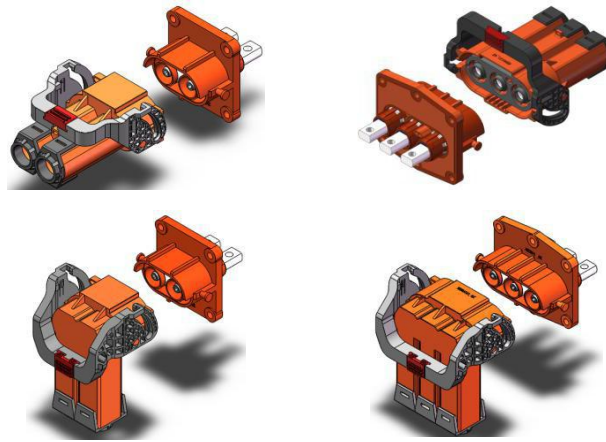

Operation Instruction

Notice: Operation instruction take 2-pin connector as an example. For assembly of 3-pin connector, please refer to the corresponding 2-pin products.

2-Pin 180° Plug Assembly

1. Select wire

Please select the shield wire that meets the requirements of Table 1.1

Table 1.1

Wire Range(mm ²)	Sheath Diameter (mm)
25	Φ13.5±0.50
35	Φ14.5±0.50
50	Φ17.5±0.50

1.2 Wire Stripping

Wire stripping according to Picture 1.1, wire stripping length according to your request. Then cut eversion shield layer to the required size.

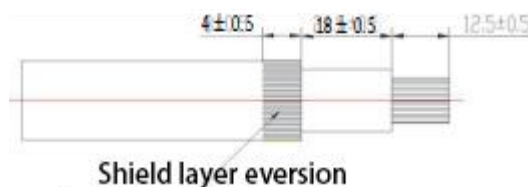

Picture 1.1

1.3 Terminal Crimp

Press the crimp terminal as shown in Picture 1.2 (recommended to be hexagonal). After crimping, the tensile strength of the terminal should not be less than that specified in Table 1.2. Then heat-shrink the tube at the crimping position and heat shrink, see Picture 1.3



Picture 1.2



Picture 1.3

Table 1.2

Wire Range(mm ²)	Tensile strength	Remark
25	≥1980N	/
35	≥2500N	/
50	≥3000N	/

1.4 Plug Assembly

Put the back cover on the wiring harness where the terminals are pressed. When covering the back cover, pay attention to the installation direction of the back cover, see Picture 1.4 for details. Put the pressed terminals (2pcs) into the

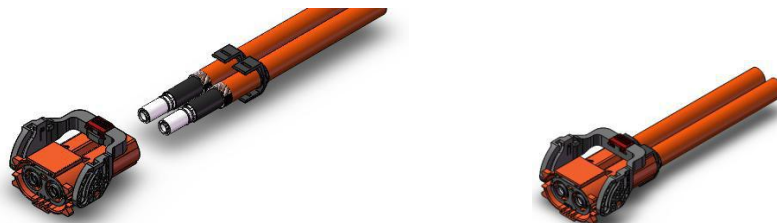

connector and install them in place. , And then close the back cover, the product is assembled, as shown in Picture 1.5.

Picture 1.4

Picture 1.5

1.5 Test

Test connector should meet below requirement

Insulation Resistance: 500MΩ

Withstand Voltage: 3000V DC

Ingress Protection: IP67

Shield layer continuity: the shield and the shell should be electrically conductive.

2-Pin 90° Plug Assembly

2.1 Select Wire

Please select the shield wire that meets the requirements of above **Table 1.1**

2.2 Wire stripping according to Picture 2.1, wire stripping length according to your request.

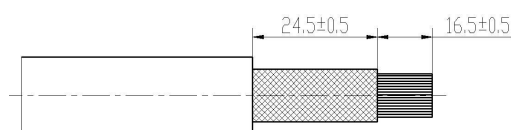

Picture 2.1

2.3 Install Back Cover and Sealing Ring

Put the back cover and sealing ring on the wire in order.

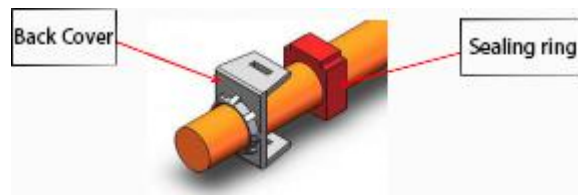

Picture 2.2

2.4 Install Shield Support Ring

Put the shield support ring on the wire as shown in Picture 2.3, and then straighten out the shield as shown in Picture 2.4, make shield layer eversion and trim it to size.

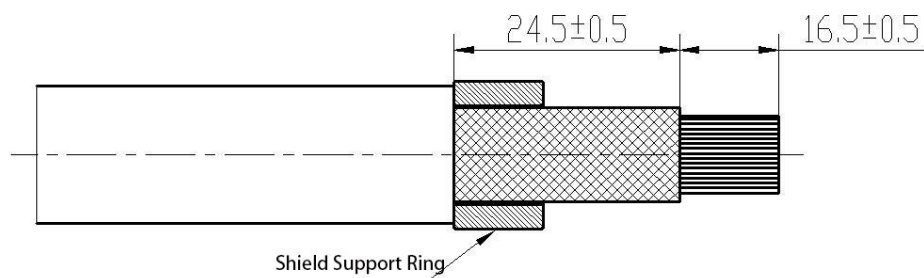

Picture 2.3

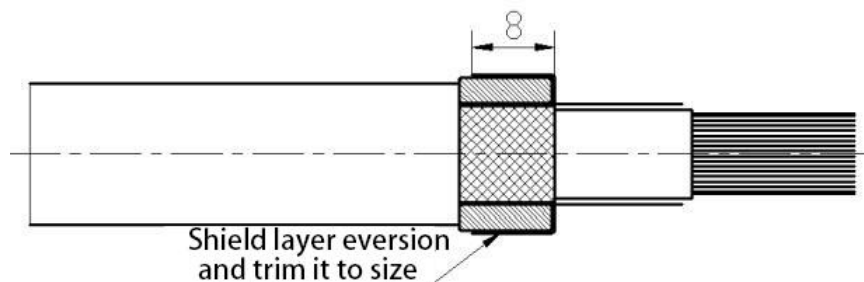

Picture 2.4

2.5 Terminal Crimp

As shown in Picture 2.5, crimp the hole crimping tube and the wire together. The crimping strength should meet the requirements of above **Table 1.2**, and then put a heat shrink tube in the position shown in the figure and heat shrink.

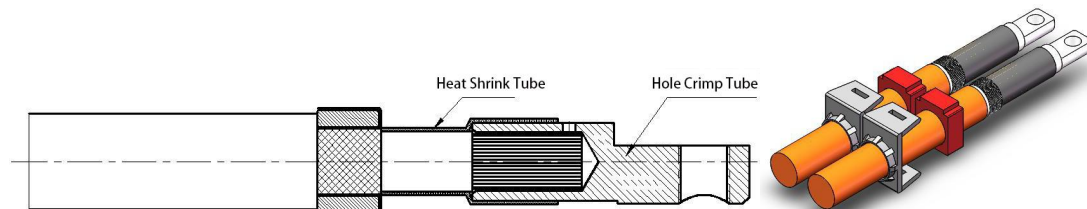

Picture 2.5

2.6 Plug Assembly---1

Install the crimped cable terminal (as shown in Picture 2.5) into the 90° plug housing combination. When installing, pay attention to keep the flat surface of the terminal parallel to the mating surface of the housing, see Picture 2.6

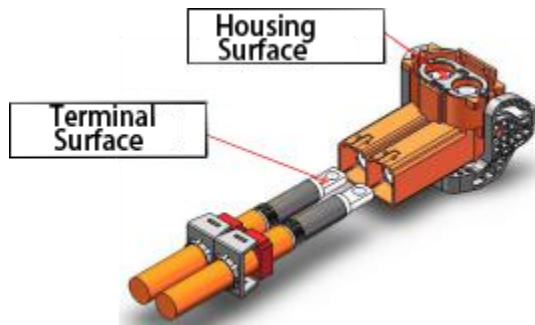

Picture 2.6

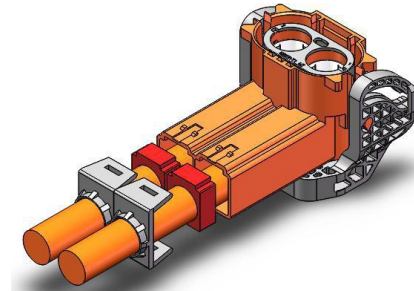

Picture 2.7

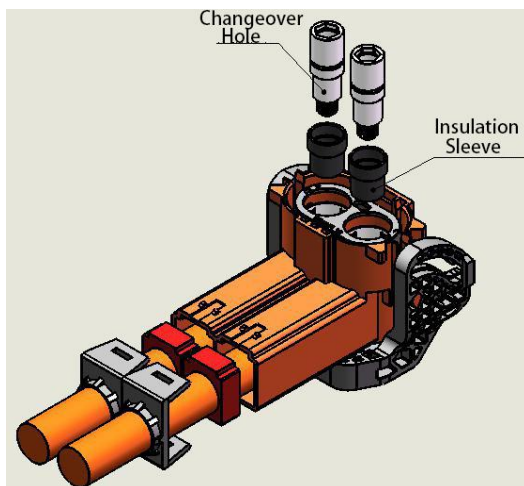

Picture 2.8

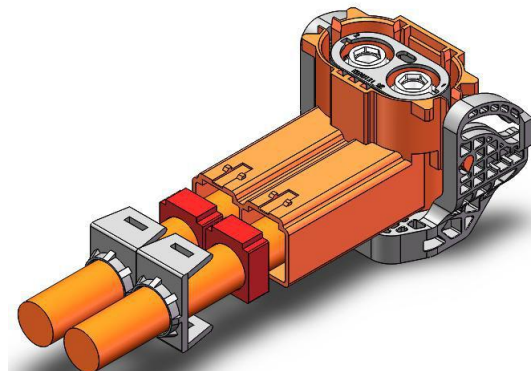

Picture 2.9

Above Picture 2.8, First install the insulation sleeve of the hole, then insert the changeover hole and screw the changeover hole onto the hole crimping barrel tube. (Note: do not tighten it for now), see Figure 2.9 for details.

2.6.1 Plug Assembly---2

When assembling the seal on the wiring harness, don't use sharp tools to avoid damage to the seal. Seal assembly in place is shown in Figure 2.10

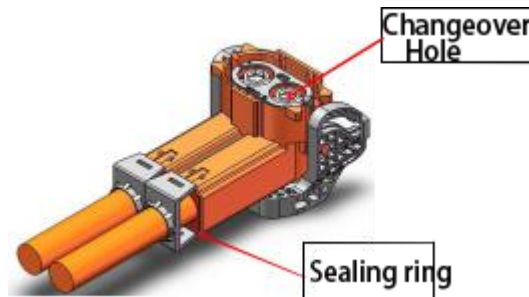

Picture 2.10

2.6.2 Plug Assembly---3

Use a torque wrench to tighten the changeover hole with a tightening torque of $8 \pm 0.5\text{N.m}$, and then cover the socket with an insulation sleeve, see Picture 2.11 for details.

Notice: The size of the inner hexagon of the adapter jack is S9. You can use S9's hexagon wrench to remove the six sharp corners before use. (See the arrow in Picture 2.11). Assemble the adapter jack, and then cover the socket with insulation For details, see Picture 2.12.

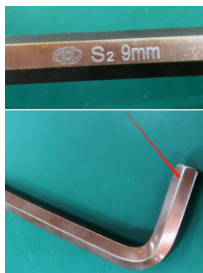

Picture 2.11

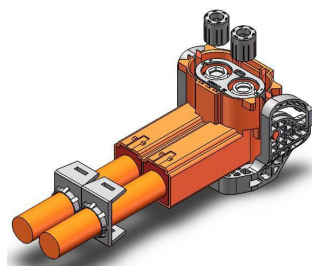

Picture 2.12

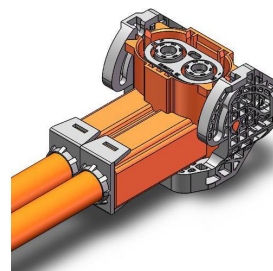

Picture 2.13

Fasten the insulating sleeve on the jack to the changeover hole. Pay attention to the direction of the insulating sleeve on the jack when buckling. Finally, close the back cover, and the product is assembled, as shown in Picture 2.13.

Notice:

- Fasten the insulating sleeve on the jack to the changeover hole. Pay attention to the direction of the insulating sleeve on the jack when buckling. Finally, close the back cover, and the product is assembled, as shown in Picture 2.13.
- There is a hexagonal structure in the insulating sleeve on the jack (see Picture 2.14), which cooperates with the hexagon of the changeover hole (see Picture 2.15).

When assembling the insulating sleeve on the jack, first place the insulating

sleeve on the jack on the adapter jack, and then press and hold the insulating sleeve on the jack and rotate it at the same time. The insulating sleeve on the jack will slide down and snap into place



Picture 2.14

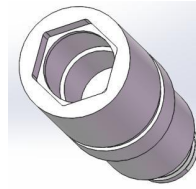

Picture 2.15

c. When assembling the back cover, as shown in Picture 2.16 and Picture 2.17, the ribs on the rear cover should be aligned with the grooves at the rear of the plug housing, and then the rear cover should be pushed in. The rear cover should be assembled in place. 2.18.

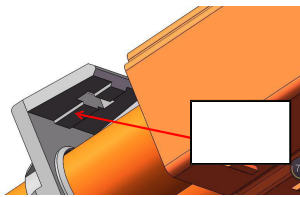

Picture 2.16

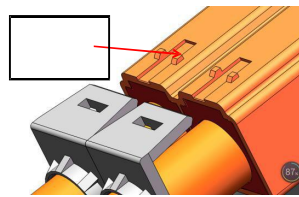

Picture 2.17

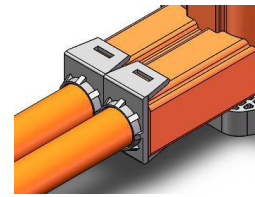

Picture 2.18

3. Test

Test connector should meet below requirement

Insulation Resistance: 500MΩ

Withstand Voltage: 3000V DC

Ingress Protection: IP67

Shield layer continuity: the shield and the shell should be electrically conductive.

Thank you to read this documents. During use progress, any question please feel free to contact us as below:

Company: Guizhou KeRuiXi Electronic Technology Co., Ltd.

Address: Building 6, High-end Equipment Manufacturing Industrial Park, Gui'an New District,

Guiyang City, Guizhou Province

China

Contact person: Amber Tan (Sales manager)

Email: sales@cnconnectors.com

technical@cnconnectors.com

Tel: 86-531-88987670

Phone: 86-13173007052