

## KRX16 Series 2-Pin/3-Pin Connector Operation Instruction

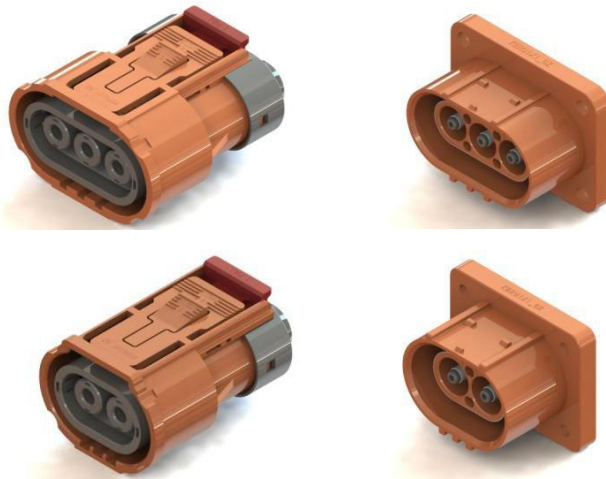

# Operation Instruction

Notice: Operation instruction take 2-pin connector as an example. For assembly of 3-pin connector, please refer to the corresponding 2-pin products.

## Unshielded Plug Assembly

### 1.1 Plug composition

The plug is composed of a plug housing, a plug hole combination, a wiring harness sealing ring, and a back cover, as shown in Picture 1.1 below. The product's delivery status is part supply

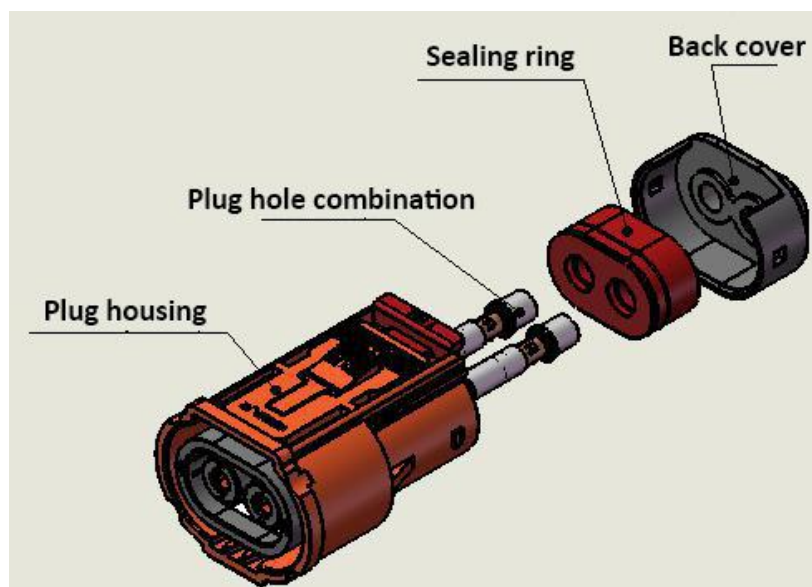

Picture 1

### 1.2 Select wire, Wire stripping, Cross wire and Wire crimp

#### 1.2.1 Select Wire

Please select the wire that meets the requirements of Table 1.1

Table 1.1

Wire Range(mm <sup>2</sup> )	Sheath Diameter (mm)	Wire Stripping size (A)
2.5	Φ3.3±0.20	5.5 <sup>+0.5</sup>
4.0	Φ4.1±0.20	5.5 <sup>+0.5</sup>
6.0	Φ4.8±0.20	5.5 <sup>+0.5</sup>
10.0	Φ6.25±0.25	5.5 <sup>+0.5</sup>

Notice: Use of over-specified (outer diameter) wire will result in product assembly failure or poor sealing

### 1.2.2 Wire Stripping

Wire stripping according to Picture 1.2, wire stripping size according to Table 1.1



Picture 1.2

### 1.2.3 Cross Wire

Put the back cover and wiring harness sealing ring on the wires in order, see below Picture 1.3

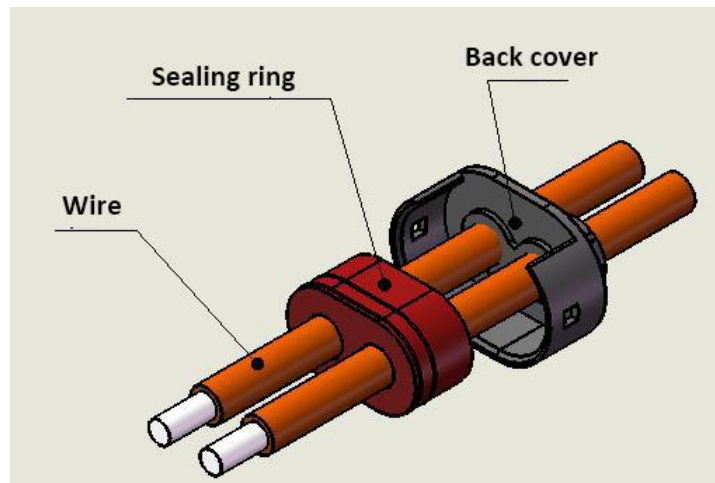

Picture 1.3

Notice: The back cover is engraved with a hole mark. When threading, the corresponding wire should be threaded into the corresponding hole according to the function definition of the terminal.

### 1.2.4 Wire Crimp

Notice: For wire crimping, a hexagonal crimping die is recommended. The recommended indentation length is 4.5-5mm. The tensile strength of the terminal after crimping is not less than that specified in Table 1.2.

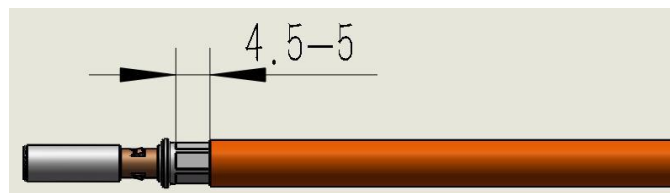

Picture 1.4

After the crimping is completed, a suitable heat-shrinkable tube is sleeved on the crimping part and heat-shrunk. The length of the heat-shrinkable tube is recommended to be 10mm. After the heat-shrinkable tube is heat-shrinkable, it should be able to completely surround the terminal indentation, See Picture 1.5.



Picture 1.5

Table 1.2

Wire Range(mm <sup>2</sup> )	Tensile strength	Remark
2.5	222.5N	/
4.0	311.5N	/
6.0	356N	/
10.0	400.5N	/

## 2. Plug Assembly

### 2.1 Install plug hole combination

Install the plug hole combination into the plug housing combination. After the plug hole combination is assembled in place, the cable should be pulled back slightly. If the plug hole combination is pulled out, it means that the plug hole combination is not assembled in place. At this time, the plug hole combination can be rotated and reinstalled until the jack is inserted. The combination cannot be pulled out.

**Notice:** When the plug hole combination card is installed in place, the positioning claw on the plug hole combination will emit a slight sound to indicate.

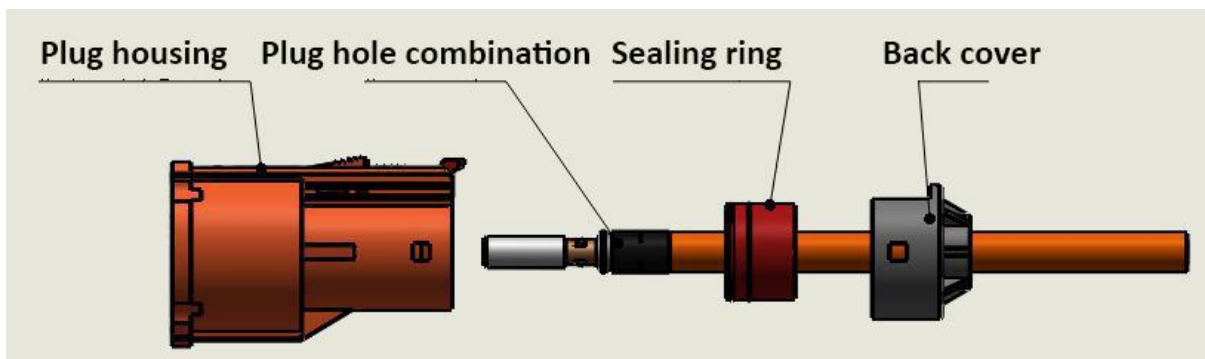

Picture 1.6

## 2.2 Install wire harness sealing ring and back cover

Install harness seals, back cover in order, the assembled product see Picture 1.7

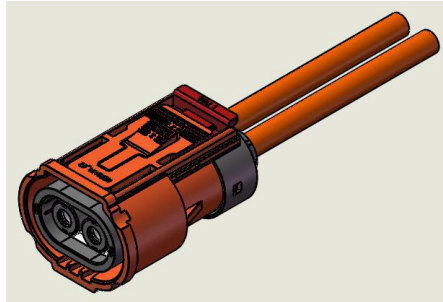

Picture 1.7

**Notice:** If it is difficult to shrink the back cover, you can assemble it with auxiliary equipment such as a hand punch, to ensure that the buckle on the back cover and the plug shell are properly engaged, as shown in Picture 1.8.

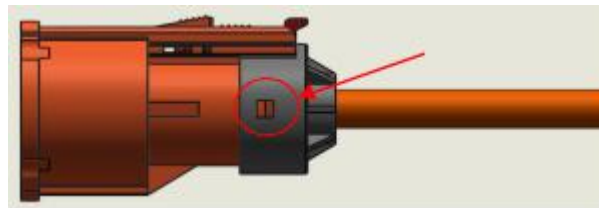

Picture 1.8

## 2.3 Electrical Performance Test

Test connector should meet below requirement

Insulation Resistance: 500MΩ

Withstand Voltage: 3000V DC

## Shield Plug Assembly

### 3.1 Assembly specification for 2.5 mm<sup>2</sup>, 4.0 mm<sup>2</sup>, 6.0mm<sup>2</sup> shield wire plug

The plug is composed of a plug housing, a plug hole combination, a shield ring, a wiring harness sealing ring, and a back cover, as shown in Picture 2.1 below. The product's delivery status is part supply.

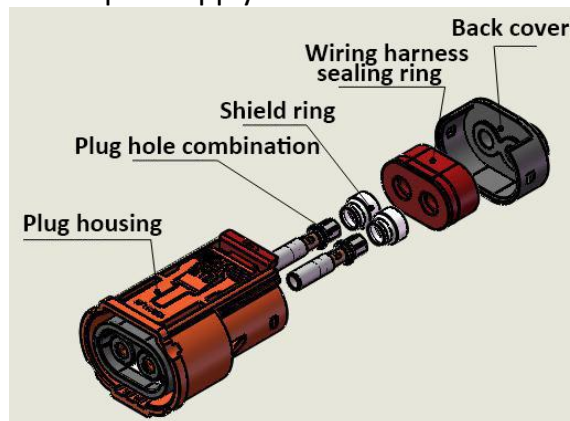

Picture 2.1

### 3.2 Select wire, Wire stripping, Cross wire and Wire crimp

#### 3.2.1 Select Wire

Please select the wire that meets the requirements of Table 2.1

Table 2.1

Wire Range(mm <sup>2</sup> )	Sheath Diameter (mm)	Wire Stripping size (A)		
		A	B	C
2.5	Φ5.2±0.20	5.5 <sup>+0.5</sup>	5 <sup>+0.5</sup>	3.1 <sup>+0.5</sup>
4.0	Φ5.8±0.20	5.5 <sup>+0.5</sup>	5 <sup>+0.5</sup>	3.1 <sup>+0.5</sup>
6.0	Φ6.7±0.30	5.5 <sup>+0.5</sup>	3.5 <sup>+0.5</sup>	3.1 <sup>+0.5</sup>

**Notice: Use of over-specified (outer diameter) wire will result in product assembly failure or poor sealing**

#### 3.2.2 Wire Stripping

Strip the wire according to the size requirements in Picture 2.2, and then turn the shield out and cut off the excess shielded wires according to the size.

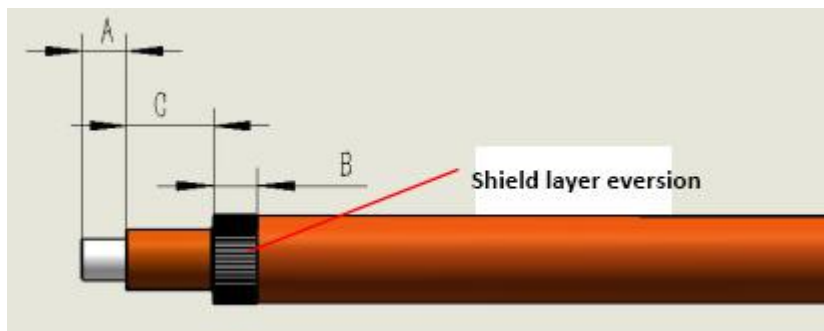

Picture 2.2

#### 3.2.3 Install shield ring

Put the shield ring on the cable as shown in Picture 2.3. The shield ring should be put to the end. The shielded wire should not be exposed after putting the shield ring on.



Picture 2.3

### 3.2.4 Crimped shield ring

Crimp the shield ring as shown in Picture 2.4. The tensile strength of the shield ring after crimping is not less than 50N, and the crimp size meets the requirements.



Picture 2.4

### 3.2.5 Terminal crimp

Crimp the terminal as shown in Picture 2.5. The tensile strength of the terminal after crimping is not less than that specified in Table 2.2, and the dimensions meet the requirements.

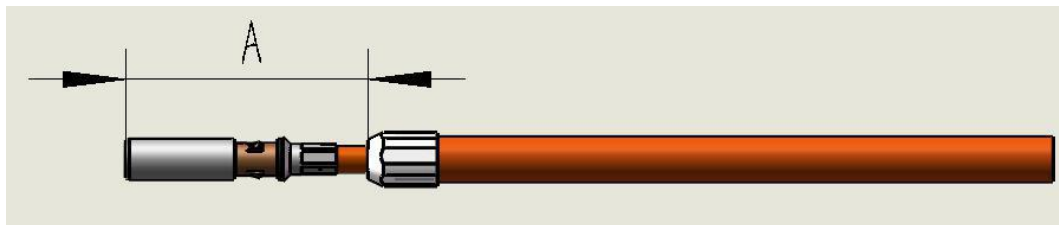

Picture 2.5

Table 2.2

Wire Range(mm <sup>2</sup> )	Tensile strength	Remark
2.5	222.5N	31.4 <sup>+0.3</sup>
4.0	311.5N	31.4 <sup>+0.3</sup>
6.0	356N	31.4 <sup>+0.3</sup>

After the crimping, put a suitable heat-shrinkable tube on the crimping part and heat-shrink. The length of the heat-shrinkable tube is recommended to be 10mm. After the heat-shrinkable tube is heat-shrinkable, it should be able to completely surround the terminal indentation, as shown in Picture 2.6.

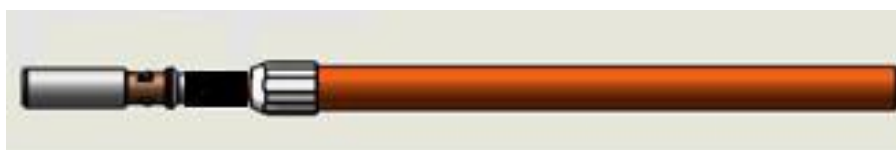

Picture 2.6

### 3.2.6 Cross Wire

Put the back cover and wiring harness sealing ring on the wires in order. **Please refer to above document [1.2.3 Cross Wire](#)**

### 3.2.7 Plug Assembly

**Please refer to above document [3. Plug Assembly](#)**

### 3.3 Test

The measurement of the insulation resistance and withstand voltage between the terminals of the connector and between any terminal and the shield should meet the following requirements

\* Insulation Resistance: 500MΩ

\* Withstand Voltage: 3000V DC

Shield layer continuity: the shield and the shell should be electrically conductive

### 4.1 Assembly specification for 10mm<sup>2</sup> shield wire plug

The plug is composed of a plug housing, a plug hole combination, ground plate, a wiring harness sealing ring, and a back cover, as shown in Picture 3.1 below. The product's delivery status is part supply.

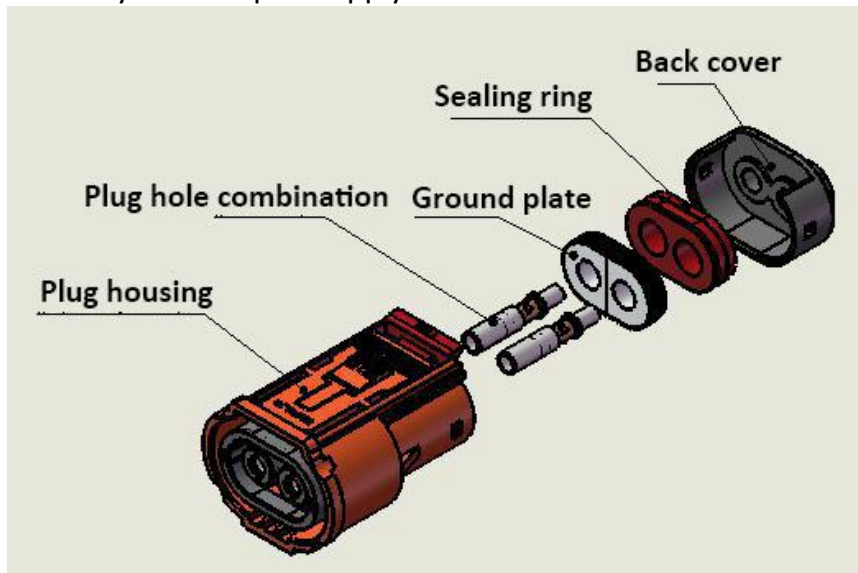

Picture 3.1

#### 4.1.1 Select Wire

Please select the wire that meets the requirements of Table 3.1

Table 3.1

Wire Range(mm <sup>2</sup> )	Sheath Diameter (mm)	Remark
10.0	8.6±0.30	/

#### 4.1.2 Wire Stripping

Strip the wire according to the size requirements in Picture 3.2, and when stripping the sheath, keep the shield layer, and then straighten the shield wire

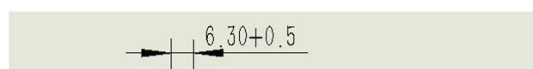



Picture 3.2

#### 4.1.3 Terminal crimp

Crimp the terminal as shown in Picture 3.3. The tensile strength of the terminal after crimping is not less than 400.5N.

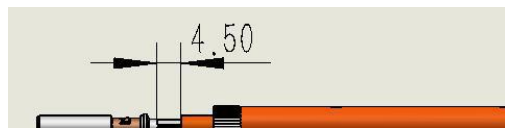

Picture 3.3

After the crimping is completed, a suitable heat-shrinkable tube is sleeved on the crimping part and heat-shrunk. The length of the heat-shrinkable tube is recommended to be 10mm. After the heat-shrinkable tube is heat-shrinkable, it should be able to completely wrap the terminal indentation, see Picture 3.4



Picture 3.4

#### 4.1.4 Install back cover, wire harness sealing ring and ground plate

As shown in Picture 3.5, put the back cover, sealing ring, and ground plate on the wire in order and assemble as shown in the figure. Finally, straighten the shielding layer.

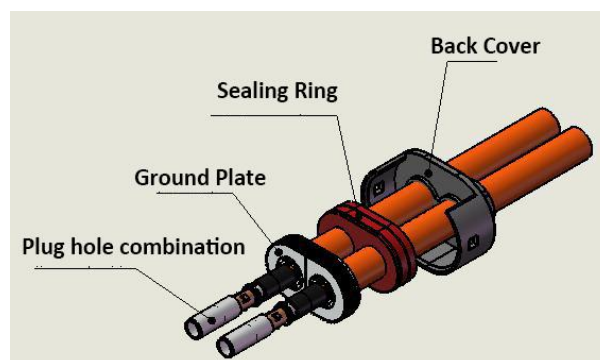

Picture 3.5

#### 4.1.5 Prune Shield layer

Adjust the grounding plate to the position shown in Picture 3.6, then straighten and wrap the shielding layer on the grounding plate, and trim the shielding layer along the edge of the grounding plate

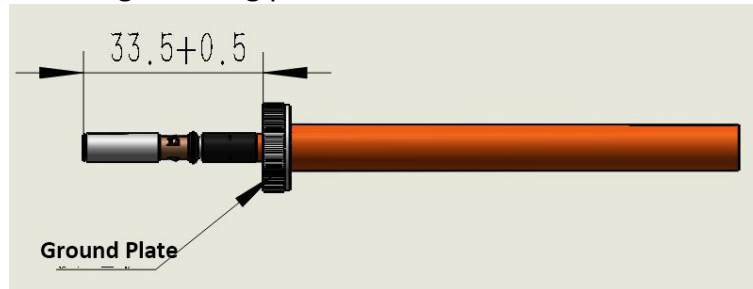

Picture 3.6

#### 4.1.6 Plug Assembly

Insert the terminal of the pressed wire into the connector, then straighten out the shielding layer again, then install the grounding plate, wiring harness sealing ring, and finally close the back cover, as shown in Picture 3.7 and Picture 3.8.

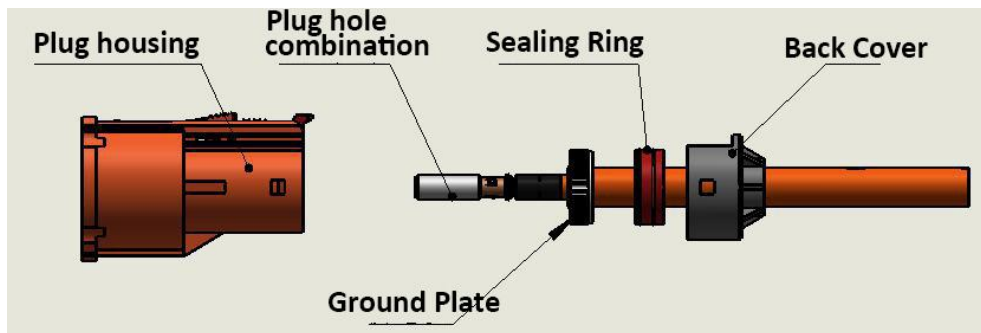

Picture 3.7

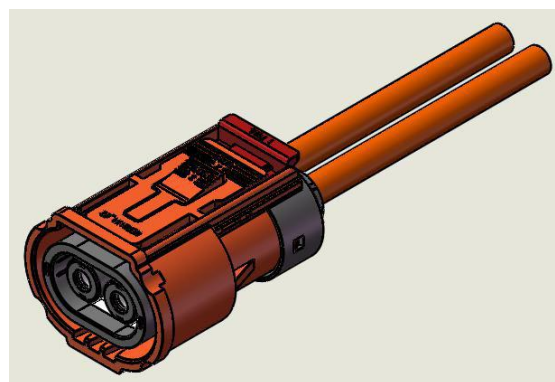

Picture 3.8

**Notice:** If it is difficult to shrink the back cover, you can assemble it with auxiliary equipment such as a hand punch, to ensure that the buckle on the back cover and the plug shell are properly engaged, as shown in Picture 3.9.

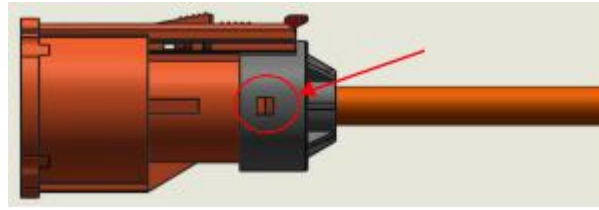

Picture 3.9

#### 4.2 Test

The measurement of the insulation resistance and withstand voltage between the terminals of the connector and between any terminal and the shield should meet the following requirements

\* Insulation Resistance: 500MΩ

\* Withstand Voltage: 3000V DC

Shield layer continuity: the shield and the shell should be electrically conductive.

### Receptacle Assembly

#### 5.1 Select wire, Wire stripping, Wire crimp

5.1.1 Select wire, Wire stripping, please meet above document [1.2.1 Select Wire and Table 1.1](#) requirement.

5.1.2 Wire stripping, please meet above document [1.2.2 Wire Stripping and Table 1.1](#) requirement.

#### 5.2 Terminal Crimp

#### 5.3 Receptacle Assembly

Insert the terminal of the pressed cable into the connector, see Picture 4.1. The assembled product is shown in Picture 4.2.

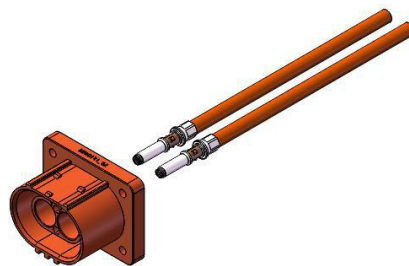

Picture 4.1

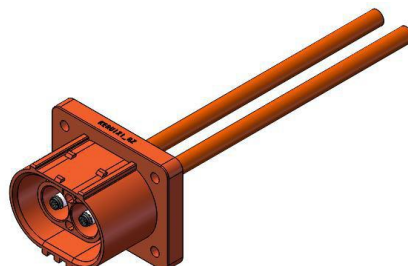

Picture 4.2

## 5.4 Test

### 5.4.1 Unshielded Receptacle Test

Measuring the insulation resistance and withstand voltage of the connector should meet the requirements

\* Insulation Resistance: 500MΩ

\* Withstand Voltage: 3000V DC

### 5.4.2 Shield Receptacle Test

The measurement of the insulation resistance and withstand voltage between the terminals of the connector and between any terminal and the shield should meet the following requirements

\* Insulation Resistance: 500MΩ

\* Withstand Voltage: 3000V DC

Shield layer continuity: the shield and the shell should be electrically conductive.

Thank you to read this documents. During use progress, any question please feel free to contact us as below:

Company: [Guizhou KeRuiXi Electronic Technology Co., Ltd.](#)

Address: Building 6, High-end Equipment Manufacturing Industrial Park, Gui'an New District,

Guiyang City, Guizhou Province

China

Contact person: Amber Tan (Sales manager)

Email: [sales@cnconnectors.com](mailto:sales@cnconnectors.com)

[technical@cnconnectors.com](mailto:technical@cnconnectors.com)

Tel: 86-531-88987670

Phone: 86-13173007052

Guizhou KeRuiXi Electronic Technology Co., Ltd. Phone: +86-13173007052

Email: [sales@cnconnectors.com](mailto:sales@cnconnectors.com)